

MITSUBISHI ELECTRIC
MITSUBISHI HOME THEATER PROJECTOR

ILLUMINATION.
DEFINITION.
DIAMOND.

Specifications

| | | | |
|---------------------------------|--|---|--------------------------|
| Model | | HC6500 | |
| Projection system | | Transmissive liquid crystal system | |
| Panel specs | Panel size | 0.74type x3 Aspect ratio 16:9 with micro lens | |
| | Number of pixels | 1920x1080 (total 2,073,600 pixels) | |
| | Drive system | 3 primary color liquid crystal shutter system | |
| Optical specs | Array | Stripe pattern | |
| | Zoom / focus operation | 1.6-power zoom / motorized | |
| | Lens shift | Motorized up-down 75% / right-left 5% | |
| | Throw ratio | 1.42-2.26 | |
| | Projection lens | f=23.5-37.6mm / 0.9"-1.5" F1.8-2.3 | |
| | Light source lamp | 160W | |
| | Optical system | Mirror color separation / prism synthesis system | |
| Projection screen size (inches) | Brightness (lm) | 1200 | |
| | Contrast ratio | 15000:1 (auto-iris) typ. | |
| | Resolution | VGA* 640x480 - UXGA* 1600x1200 | |
| Images | Scan frequency | Horizontal (kHz) | 15-100kHz |
| | | Vertical (Hz) | 24, 50Hz-120Hz |
| Input signal system | Video | NTSC, NTSC4.43, PAL (including PAL-M and N), SECAM, PAL-60 Video input: 480i/p, 576i/p, 1080i 60/50, 1080p 60/50/24, 720p 60/50 | |
| | PC | PC/AT compatibles, Mac | |
| Input | Video | PC input | Mini D-Sub 15 pin |
| | | HDMI input | HDMI terminal |
| | | Composites | RCA terminal |
| | | S | S-Video terminal |
| | | Components | RCA terminal |
| | | Serial / RS-232C standard | 1 terminal (D-Sub 9 pin) |
| Output | Trigger terminal | 1 terminal | |
| Functions | Digital keystone | Vertical ±15steps | |
| | Fan noise | 17dBA (at low mode) | |
| | Power source voltage | AC100V 50/60Hz | |
| | Power consumption (W) | 250 (at stand by 7W) | |
| | Weight (kg / lbs) | 7.5 / 16.5 | |
| Other | Main unit dimensions | WxDxH 427x440x159mm / 16.8"x17.3"x6.3" (excluding height adjustment) | |
| | Supplied accessories | Power source cord (2.9m), Remote control, AA batteries (x2), RGB signal cable, RS-232C cable, Lens cap, Lamp replacement tray | |
| Warranty | 2-years parts and labor, 1-year or 500 hours on lamp (whichever comes first) | | |

*: SVGA, XGA, WXGA, SXGA, UXGA are registered trademarks of IBM Corporation of the United States

Projection distance

| Screen size (16:9) | | | | Projection distance | | | | Up-down lens shift | | Right-Left lens shift | | | | | | | | | | |
|--------------------|-----------|------------|----------|---------------------|------|---------------|---------------|--------------------|----------|-----------------------|------------|------------|----------|----------|------|------|------|-------|-----------------|---------------|
| Diagonal | W (width) | H (height) | Max Zoom | Min Zoom | Down | Up | Left | Right | Diagonal | W (width) | H (height) | Black zone | Max Zoom | Min Zoom | Down | Up | Left | Right | | |
| inch | cm | inch | inch | inch | inch | inch | inch | inch | inch | inch | inch | inch | inch | inch | inch | inch | inch | inch | inch | |
| 50 | 127 | 43.7 | 24.4 | 59 | 98 | 19 ← 0 → 19 | 2.4 ← 0 → 2.4 | 2.4 | 50 | 127 | 40.2 | 29.9 | 46.1 | 40.2 | 22.4 | 3.9 | 55 | 91 | 16.9 ← 0 → 16.9 | 1.9 ← 0 → 1.9 |
| 60 | 152 | 52.4 | 29.5 | 71 | 118 | 22 ← 0 → 22 | 2.8 ← 0 → 2.8 | 2.8 | 60 | 152 | 48.0 | 35.8 | 55.1 | 48.0 | 27.2 | 4.3 | 67 | 106 | 20.0 ← 0 → 20.0 | 2.4 ← 0 → 2.4 |
| 70 | 178 | 61.0 | 34.3 | 87 | 138 | 26 ← 0 → 26 | 3.1 ← 0 → 3.1 | 3.1 | 70 | 178 | 55.9 | 42.1 | 64.2 | 55.9 | 31.5 | 5.1 | 79 | 126 | 23.6 ← 0 → 23.6 | 2.8 ← 0 → 2.8 |
| 80 | 203 | 69.7 | 39.4 | 98 | 158 | 30 ← 0 → 30 | 3.5 ← 0 → 3.5 | 3.5 | 80 | 203 | 64.2 | 48.0 | 73.6 | 64.2 | 35.8 | 5.9 | 91 | 148 | 27.2 ← 0 → 27.2 | 3.1 ← 0 → 3.1 |
| 90 | 229 | 78.3 | 44.1 | 110 | 177 | 33 ← 0 → 33 | 3.9 ← 0 → 3.9 | 3.9 | 90 | 229 | 72.0 | 53.9 | 82.7 | 72.0 | 40.6 | 6.7 | 102 | 161 | 30.3 ← 0 → 30.3 | 3.5 ← 0 → 3.5 |
| 100 | 254 | 87.0 | 49.2 | 122 | 197 | 37 ← 0 → 37 | 4.3 ← 0 → 4.3 | 4.3 | 100 | 254 | 79.9 | 59.8 | 91.7 | 79.9 | 44.9 | 7.5 | 114 | 181 | 33.9 ← 0 → 33.9 | 3.9 ← 0 → 3.9 |
| 110 | 279 | 96.1 | 53.9 | 134 | 217 | 41 ← 0 → 41 | 4.7 ← 0 → 4.7 | 4.7 | 110 | 279 | 88.2 | 66.1 | 101 | 88.2 | 49.6 | 8.3 | 122 | 201 | 37.0 ← 0 → 37.0 | 4.3 ← 0 → 4.3 |
| 120 | 305 | 104.7 | 58.7 | 150 | 236 | 44 ← 0 → 44 | 5.1 ← 0 → 5.1 | 5.1 | 120 | 305 | 96.1 | 72.0 | 110 | 96.1 | 53.9 | 9.1 | 134 | 217 | 40.6 ← 0 → 40.6 | 4.7 ← 0 → 4.7 |
| 130 | 330 | 113.4 | 63.8 | 161 | 256 | 48 ← 0 → 48 | 5.5 ← 0 → 5.5 | 5.5 | 130 | 330 | 104 | 77.9 | 119 | 104 | 58.7 | 9.8 | 146 | 236 | 43.7 ← 0 → 43.7 | 5.1 ← 0 → 5.1 |
| 140 | 356 | 122.0 | 68.5 | 173 | 276 | 52 ← 0 → 52 | 5.9 ← 0 → 5.9 | 5.9 | 140 | 356 | 112 | 83.9 | 128 | 112 | 62.9 | 10.6 | 158 | 256 | 47.2 ← 0 → 47.2 | 5.5 ← 0 → 5.5 |
| 150 | 381 | 130.7 | 73.6 | 185 | 299 | 55 ← 0 → 55 | 6.7 ← 0 → 6.7 | 6.7 | 150 | 381 | 120 | 90.2 | 138 | 120 | 67.3 | 11.4 | 169 | 272 | 50.8 ← 0 → 50.8 | 5.9 ← 0 → 5.9 |
| 200 | 508 | 174.4 | 96.0 | 248 | 398 | 74 ← 0 → 74 | 8.7 ← 0 → 8.7 | 8.7 | 200 | 508 | 160 | 120 | 183 | 160 | 90.2 | 14.9 | 228 | 366 | 67.3 ← 0 → 67.3 | 7.9 ← 0 → 7.9 |
| 250 | 635 | 217.7 | 122.4 | 311 | 496 | 92 ← 0 → 92 | 11 ← 0 → 11 | 11 | 250 | 635 | 200 | 150 | 230 | 200 | 113 | 18.9 | 284 | 457 | 84.3 ← 0 → 84.3 | 9.8 ← 0 → 9.8 |
| 300 | 762 | 261.4 | 147.2 | 374 | 598 | 110 ← 0 → 110 | 13 ← 0 → 13 | 13 | 300 | 762 | 240 | 180 | 275 | 240 | 135 | 22.4 | 343 | 547 | 101 ← 0 → 101 | 12 ← 0 → 12 |

* The above figures are approximate and may be slightly different from the actual measurements.

Vertical direction

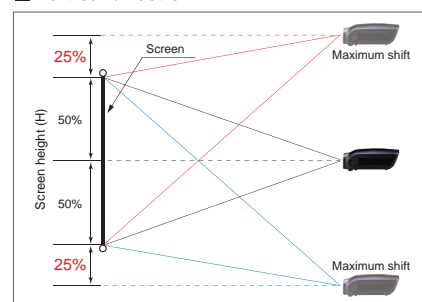

Horizontal direction

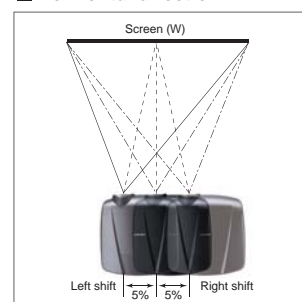

Dimensions

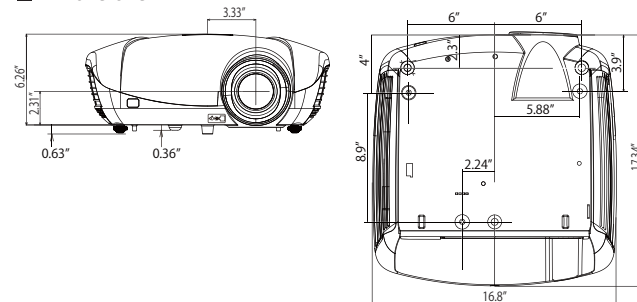

MITSUBISHI DIGITAL ELECTRONICS AMERICA, INC.
Presentation Products Division
Phone: 888.307.0349
Email: ppdinfo@mdea.com
www.mitsubishi-presentations.com

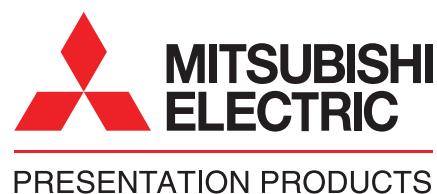

MITSUBISHI ELECTRIC SALES CANADA, INC.
Information Technologies Group
Phone: 905.475.7728
www.mitsubishielectric.ca

NEW HC6500

