

JTP Series

- Hygienic construction
- Compact modular design
- Displacement 1.63 litres/rev
- Differential Pressure to 8 bar
- Speed to 700 rpm
- Weight only 53 kg (117 lbs)
- Low weight - high displacement
- Low maintenance
- Bi directional operation
- Close coupled to drive



Universal Mounting

- Bolt on feet for universal mounting
- Pumps can be mounted with
 - Top shaft drive
 - Bottom shaft drive
 - Vertical Inlet/Outlet
 - Feet upward

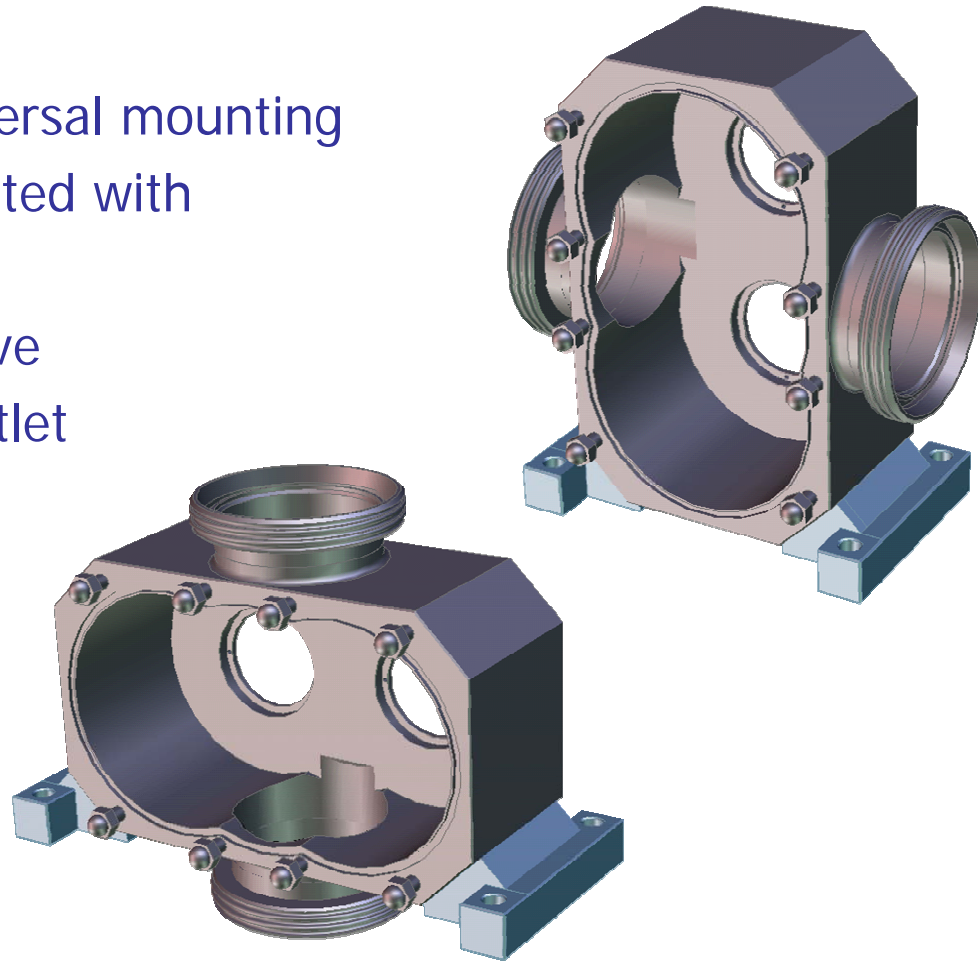

Product Seals

- All seals are front loading for fast access and optimum performance.
- The seals can be examined and cleaned by simply removing the Rotor without taking the pump from the vehicle or disconnecting pipe work.
- Even stuck rotor can easy pull out by rotor extraction tool.

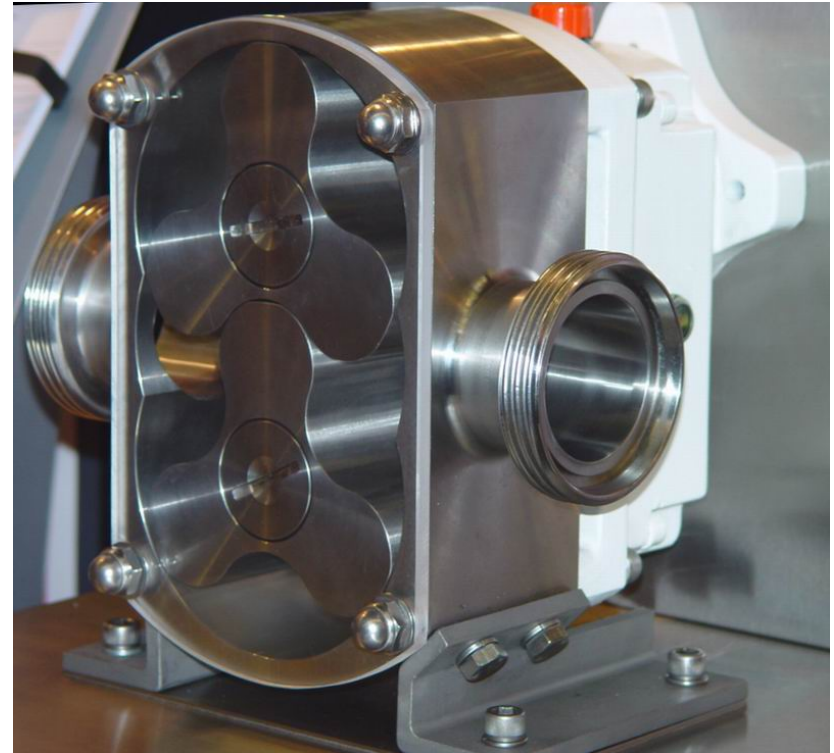

Gearbox

- Lightweight aluminium construction
- Fast and easy assembly and disassembly
- Gearbox module plugs on to Rotorcase
- Rugged location and alignment mechanisms



Relief Valve

- Pre-set internal relief valve mounted on front cover
- PTFE faced diaphragm
- Full pressure range, up to 12 bar



Drive Connection(JTP330)

- Pump close coupled to drive
- SAE A Flange, 2 or 4 bolt fixing
- Other adapters
 - Standard inside keyway
 - External shaft extension

